



Catalogue :

**COUNTERS NEO**

Chapter :

**GLOBE CONCEPT GN COUNTERS**

Article :

**EMFP-147-GN-R 230V 1N 50Hz**

Code:

**19037591**

<u>DIMENSIONS AND WEIGHTS</u>		<u>Net dimensions</u>	<u>Packed</u>
Length	mm	<b>1.492,00</b>	<b>825,00</b>
Depth	mm	<b>700,00</b>	<b>1.910,00</b>
Height	mm	<b>850,00</b>	<b>1.060,00</b>
Weight	kg	<b>99,00</b>	<b>104,00</b>
Volume	m3	<b>0,89</b>	<b>1,67</b>

<u>ELECTRICITY</u>		<u>230V</u>	<u>50Hz</u>
Power			<b>0,03 kW</b>
Connections	230 V. 1+N+T	<b>2X1,5+T - 2 A</b>	
	230 V. III+T	<b>3X4+T-32A</b>	
	400 V. III+N+T	<b>4X1,5+T-16A</b>	

GAS Not necessary

WATER Not necessary

STEAM Not necessary

AIR Not necessary

Internal gross capacity litres **428**  
 Climat class **4**

SOUND LEVEL **< 65,00 db**

CERTIFICATES **SGS-2103-0906-1**

INSTALLATION - CONNECTIONS **Ø**  
 ► ELECTRICITY **SI**

DESCRIPTION

REFRIGERATED COUNTER FOR REMOTE UNITS GASTRONORM, EMFP-147-GN-R

SPECIFICATIONS

High quality austenitic stainless steel inside and outside (except for galvanized back panel).  
 50 mm, 40 kg/m<sup>3</sup> injected polyurethane isolation.  
 Forced draught cooling system inside the room.  
 Copper piping and aluminium flaps evaporator.  
 Digital display for electronic and digital control of temperature and defrosting.  
 The controls are integrated in the front panel for a better protection against dirt. IPX5 compliant, the controls are protected against water splash and jets.  
 Opened door delay alarm.  
 Easier loading and unloading thanks to its door self-closing and stay open features.  
 Removable and height adjustable plastic covered steel shelves for easy cleaning (GN1/1 size).  
 Equipment per door: 1 GN 1/1 grid and 2 sets of height adjustable tray slides.  
 Built in drainage to get rid of waste liquids inside the unit.  
 Embedded bottom and curved panels inside for easy cleaning and maintenance.  
 Height adjustable stainless steel legs.  
 10 cm high splashback.  
 Units ready for the connection of a remote cooling unit when short of space inside the kitchen.  
 Working temperature: from -2 °C up to +8 °C.  
 Climatic class 4.

Doors: 3  
 Gross capacity: 428 L  
 Electric power: 29 W  
 Dimensions: 1492x700x850 mm





Catalogue :  
**COUNTERS NEO**

Chapter :  
**GLOBE CONCEPT GN COUNTERS**

Article :  
**EMFP-147-GN-R 230V 1N 50Hz**

Code :  
**19037591**

**SCHEMA - DIMENSIONS**

**Mod. 102R / 147R / 192R**

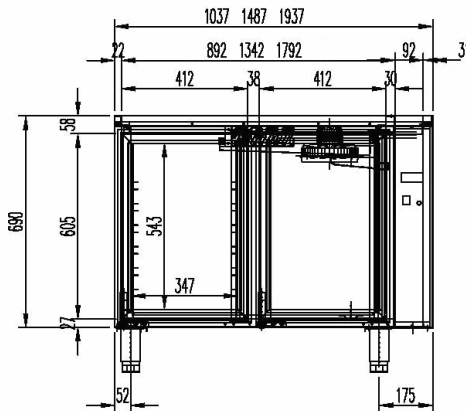
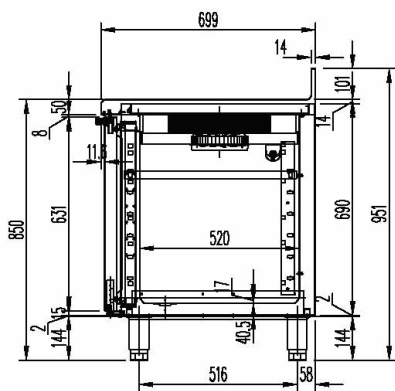

**Mod. 102R / 147R / 192R**

