



Catalogue
CATERING
Chapter
COOKING

Model
CE7-20 Q 380-415V 3N

19005253

17/12/2018

ELECTRIC RANGE, CE7-20 Q
Made of stainless steel.
Cast iron square hot- plates with shielded elements.
6 settings switch. Indicator lights.
Plates: 2 x 3,000 W (300 x 300 mm).

DIMENSIONS

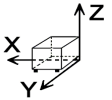

X Width	350 mm	X Gross width	390 mm
Y Depth	775 mm	Y Gross depth	885 mm
Z Height	290 mm	Z Gross height	550 mm
Net Weight	20,0 kg	Gross Weight	30,0 kg
Net volume	0,079 m3	Gross volume	0,190 m3

ELECTRICITY TECHNICAL SPECIFICATIONS

Electric power	6,000 kW
Heating power	6,00 kW
Voltage	380-415V - 3N
Amperage	9A
Electric frequency	50/60Hz



Catalogue
CATERING
Chapter
COOKING

Model
CE7-20 Q 380-415V 3N

19005253

17/12/2018

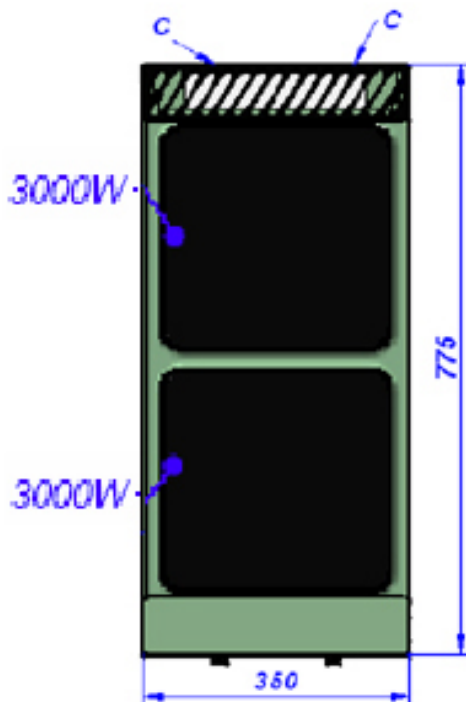
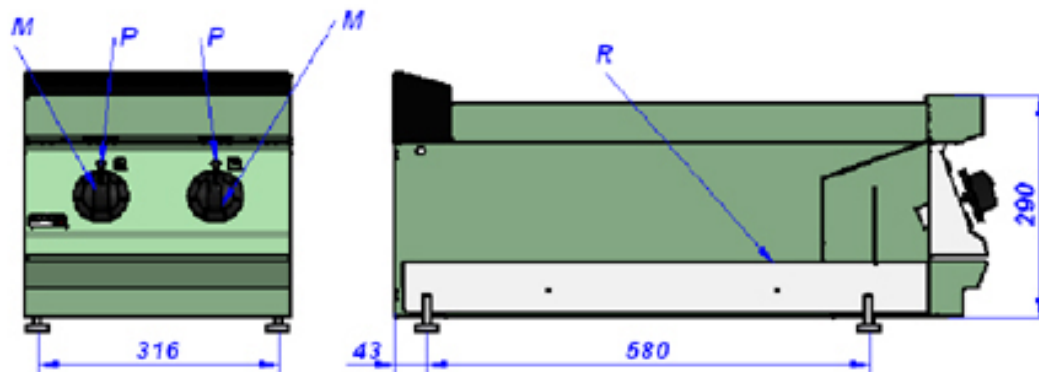

R: regleta para conexión eléctrica
M: Botón de mando de placa

R: Electrical connection switch
M: Control knob