



Catalogue
CATERING
Chapter
COOKING

Model
 B-E9101 380-415V 3N

19030319

14/12/2018

ELECTRIC GRILL TOP, B-E9101

The new Fagor industrial grills do not carbonize food surface and provide a healthy cooking.
 Our grills reach a very high temperature (400°C) that seals the product surface quickly and keeps a more juicy inside .
 Their new features include steam cooking.
 2 mm stainless AISI-304 steel top with rounded edges for easy cleaning. Laser cut and automatic welding for a perfect adjustment of sides between modules with square angle finish.
 Electric heated model with two groups of three shielded stainless steel resistances under grill surface.
 Independent power regulator for each electrical resistance group.
 Cast iron grill with four 170 mm wide sections. Easy to remove without tools for any easy cleaning.
 Reversible grill to cook different products in a different way:
 _Grooved side and slanted grill for meat.
 _Smooth flat horizontal side for fish and vegetables
 Food gets cooked and grilled from direct contact and heat irradiation from underneath burners.
 Grill surface 48 dm²
 Fitted with two cooking fat drainage holes at the front to collect fat and grease from cooking, and 12 litre collecting trays at the bottom. Fat collecting trays may be filled with water. Thanks to the heat irradiated by the burners a low intensity steam is produced to cook in a steam atmosphere.
 Removable 130 mm stainless steel anti splash shield, easy to wash.
 Water-tight and protecting-support controls.
 High temperature protector for the chimney made of enamelled cast iron.
 Front access to components.
 According to European standards for components and panels temperature, efficiencies and combustion, and sanitary regulations (EN-60335 and EN-203)
 IPX5 grade water protection equipment.

DIMENSIONS

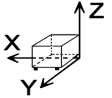

X Width	800 mm	X Gross width	840 mm
Y Depth	930 mm	Y Gross depth	1022 mm
Z Height	850 mm	Z Gross height	1265 mm
Net Weight	67,0 kg	Gross Weight	80,0 kg
Net volume	0,134 m ³	Gross volume	1,086 m ³

ELECTRICITY TECHNICAL SPECIFICATIONS

Electric power	15,000 kW
Heating power	15,00 kW
Voltage	380-415V - 3N
Amperage	25A
Electric frequency	50/60Hz

Catalogue
CATERING

Chapter
COOKING

Model
B-E9101 380-415V 3N

19030319

14/12/2018

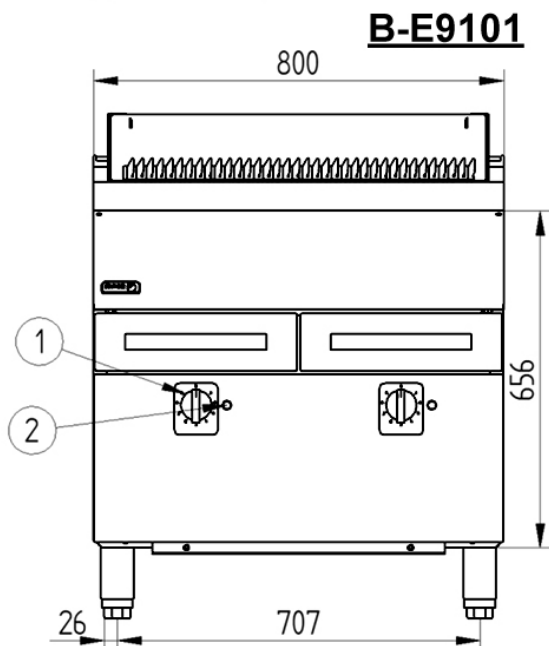
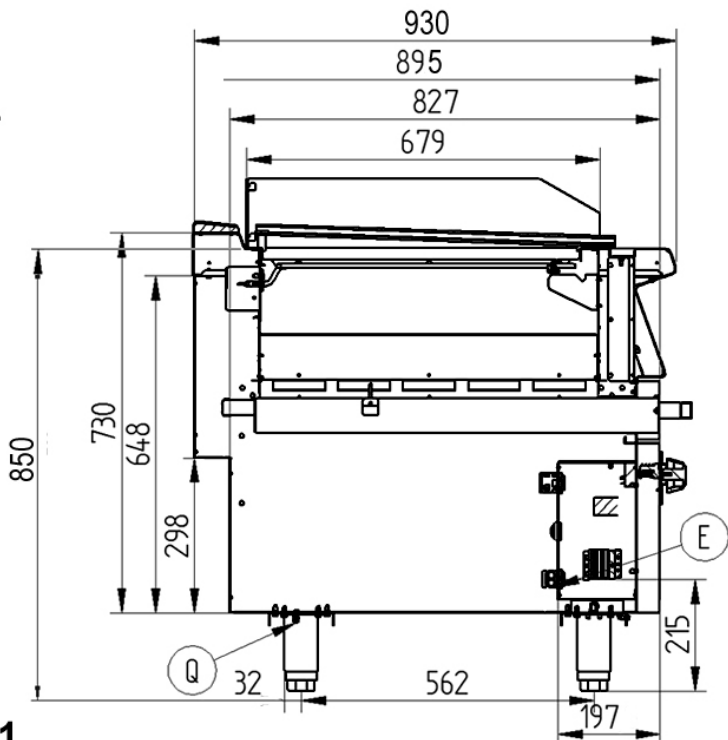
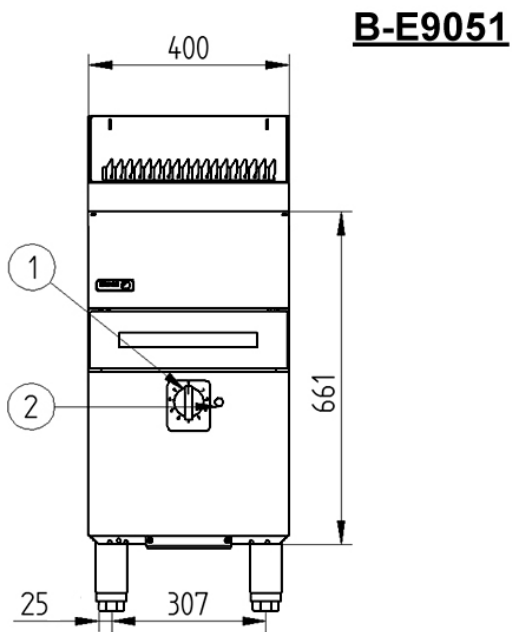

E - Conexión eléctrica
Q - Conexión equipotencial
1 - Mando eléctrico
2 - Piloto ambar

Electrical connection
Equipotential
Electric control
Ambar pilot