



Catalogue
CATERING
Chapter
OVENS

Model
 AG-201 LPG 230V 1N 50Hz

19011193

24/01/2019

GAS ADVANCE COMBI OVEN, AG-201

High quality, fast cooking :

Professional quality
 Easy to use and efficient
 perfect results
 Affordable

Capacity for 20 1/1-GN trays.

Stainless steel burner with electronic control system with sparking plug ignition.
 Frequency modulation for the convection burner.
 Push-button and "Scrolling" controls.
 5 cooking methods: Steam, Low-temperature steam, Regeneration, Combination and Convection (up to 300°C).
 Preheating option.
 Overnight cooking or low-temperature programme.
 3 Speeds - 2 power ranges.
 Cold-Down chamber cooling system.
 "Auto-reverse" system to reverse fan rotation.
 Multisensor core temperature probe.
 Steam generator equipped with limescale detector.
 Steam generator automatically empties every 24 hours of cooking.
 Semi-automatic limescale removal system.
 Error detection system. "Repair service" mode system.
 IPX-5 protection.
 AUTOMATIC CLEANING - Wash program for the cooking chamber.
 Retractable shower.
 Includes trolley with integrated structure for trays CEB-201.

Accessories in option:

trolley with integrated Structure for dishes CEP-201
 Thermal cover LTE-201

DIMENSIONS

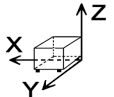

X Width	929 mm	X Gross width	1015 mm
Y Depth	964 mm	Y Gross depth	1100 mm
Z Height	1841 mm	Z Gross height	2080 mm
Net Weight	310,0 kg	Gross Weight	376,0 kg
Net volume	1,649 m3	Gross volume	2,322 m3

ELECTRICITY TECHNICAL SPECIFICATIONS

Electric power	2,400 kW
Voltage	230V - 1N
Amperage	10,4
Electric frequency	50Hz

GAS TECHNICAL SPECIFICATIONS

Gas type	LPG
Gas power	36,00 kW
Gas consumption	2,995 kg/h
Regulated	LPG G30/G31 28-30/37 mbar

WATER TECHNICAL SPECIFICATIONS

Water max consumption	30,00 L/h
Pressure	H2O: 200-400kPa(2-4bar)

OTHERS

Noise level	62,00 dB
-------------	----------

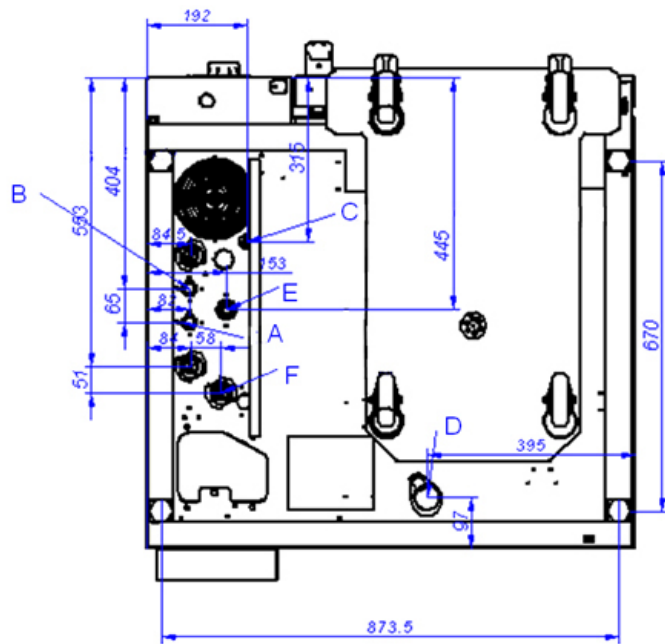
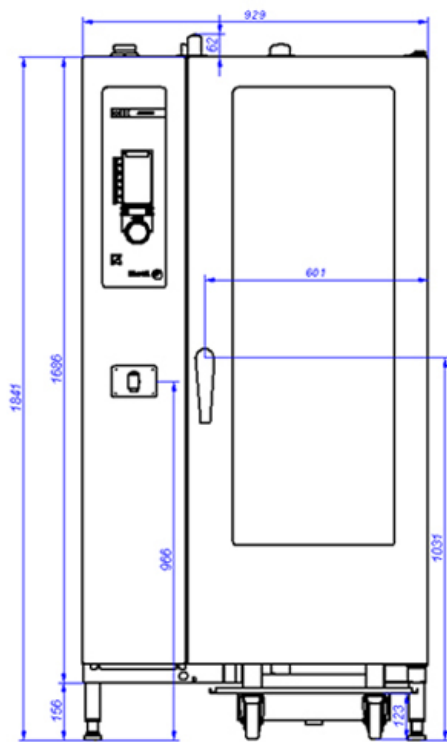

VISTA DE LA BASE DESDE LA PARTE INFERIOR
VIEW FROM THE BOTTOM OF THE MACHINE

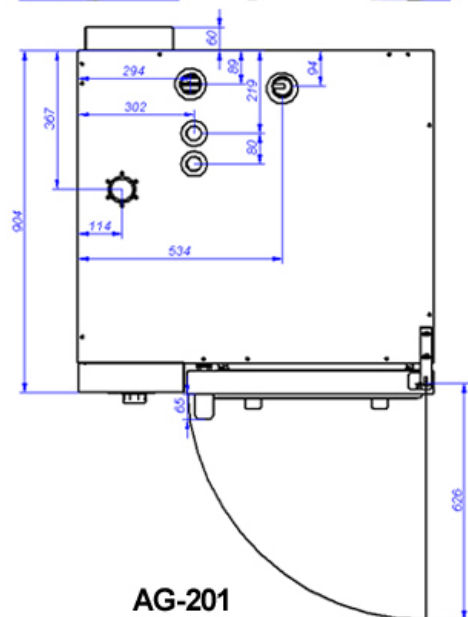

AG-201

A: Entrada de agua blanda
B: Entrada de agua dura
D: Desagüe

C: Alimentación eléctrica

E: Entrada de gas

F: Entrada de aire

A: Soft water inlet
B: Water inlet
D: Drain

C: Electrical connection

E: Gas inlet

F: Air